

MT08-F04
TECHNICAL DATA

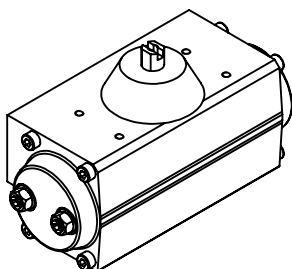

MT07-F04
DATI TECNICI

DIMENSIONS TO
ISO 5211 - DIN 3337
AND NAMUR VDI/VE 3845
DIMENSIONS IN INCHES
[MM]

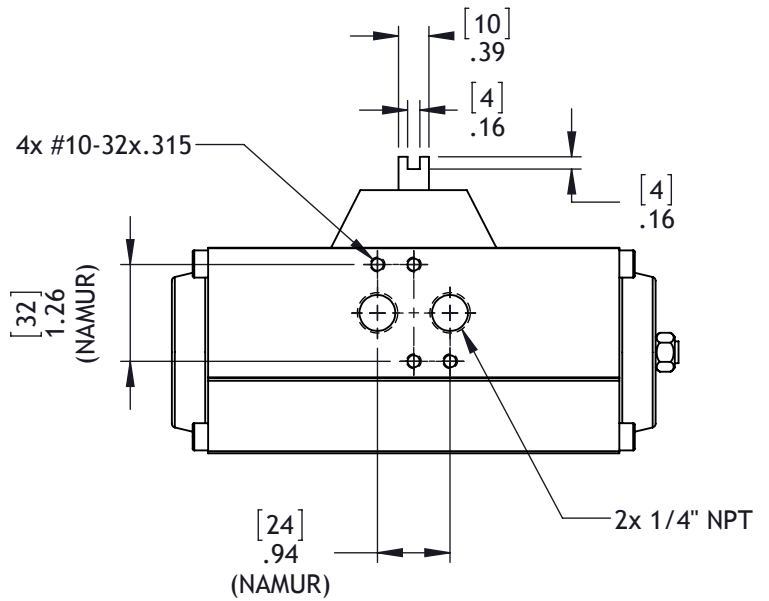
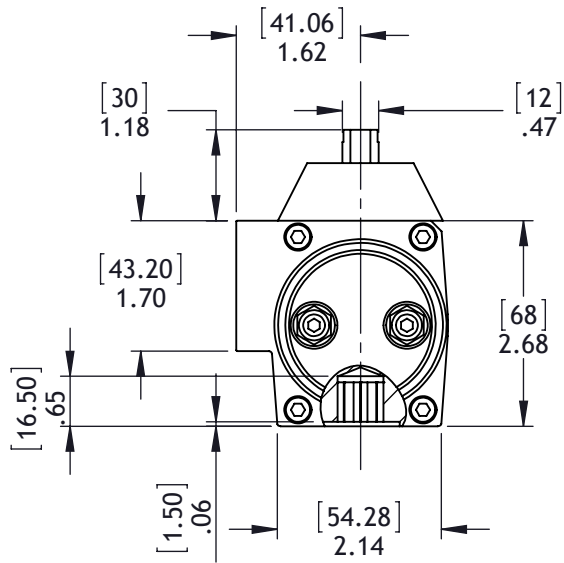
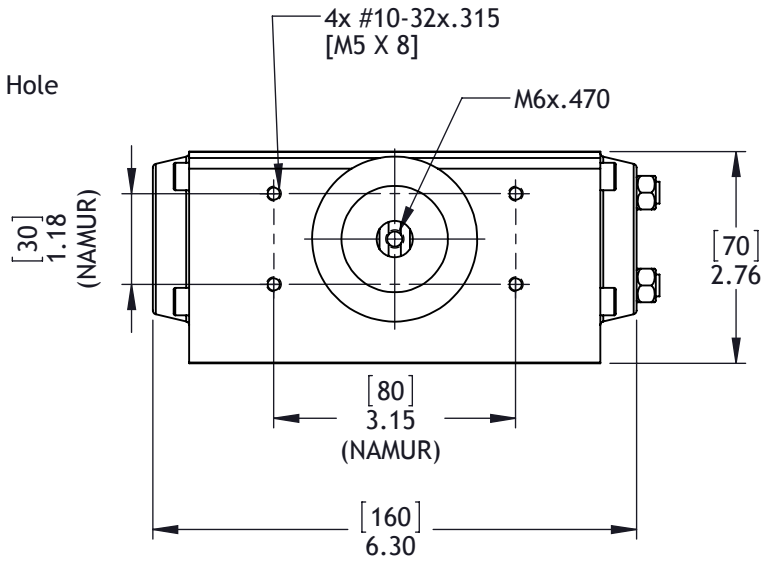
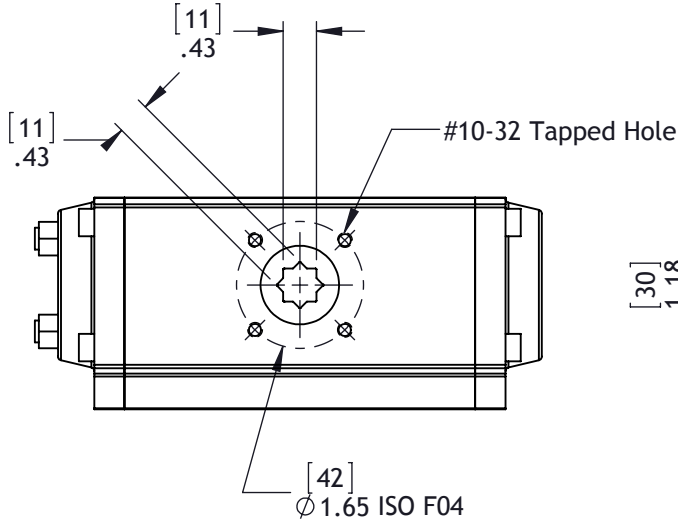

WEIGHT (LB)		AIR CONSUMPTION (CU. IN)	
D.A	S.R.	D.A.	S.R.
2.76	3.00	15.26	6.10

MT-07

VALORI DI COPPIA in "Nm" TORQUE VALUES in "Nm"

DOPPIO EFFETTO DOUBLE ACTING

100 kPa = 1 Bar

100 kPa	200 kPa	300 kPa	400 kPa	500 kPa	562 kPa	600 kPa	700 kPa	800 kPa	900 kPa	1000 kPa
--	--	12,5	16,6	20,8	23,4	25,0	29,2	33,3	--	--

SEMPLICE EFFETTO 90° SPRING RETURN 90°

100 kPa = 1 Bar

POS. 1 COPPIA DI CHIUSURA (RITORNO MOLLE) POS. 1 CLOSING TORQUE (SPRING)		POS. 2 - COPPIA DI APERTURA - POS. 2 - OPENING TORQUE																					
		200 kPa		300 kPa		400 kPa		500 kPa		562 kPa		600 kPa		700 kPa		800 kPa		900 kPa		1000 kPa			
N° MOLLE # SPRINGS	POS. 1		200 kPa		300 kPa		400 kPa		500 kPa		562 kPa		600 kPa		700 kPa		800 kPa		900 kPa		1000 kPa		
	START	END	START	END	START	END	START	END	START	END	START	END	START	END	START	END	START	END	START	END	START	END	
1+1	3,7	2,3	6,0	4,6	10,2	8,8	14,3	12,9	18,5	17,1	21,1	19,7	22,7	21,3	26,9	25,5	31,0	29,6	35,2	33,8	39,4	38,0	
2+2	7,4	4,6	--	--	7,9	5,1	12,0	9,2	16,2	13,4	18,8	16,0	20,4	17,6	24,6	21,8	28,7	25,9	32,9	30,1	37,1	34,3	
3+3	11,1	6,9	--	--	5,6	1,4	9,7	5,5	13,9	9,7	16,5	12,3	18,1	13,9	22,3	18,1	26,4	22,2	30,6	26,4	34,8	30,6	
4+4	14,8	9,2	--	--	--	--	7,4	1,8	11,6	6,0	14,2	8,6	15,8	10,2	20,0	14,4	24,1	18,5	28,3	22,7	32,5	26,9	
5+5	18,5	11,5	--	--	--	--	--	--	9,3	2,3	11,9	4,9	13,5	6,5	17,7	10,7	21,8	14,8	26,0	19,0	30,2	23,2	

MT-08

TORQUE VALUES in "IN.LB"

SPRING RETURN 90°

DOUBLE ACTING

40 PSIG	60 PSIG	80 PSIG	100 PSIG	120 PSIG
110	147	207	259	295

POS. 1 CLOSING TORQUE (SPRING)		POS. 2 - OPENING TORQUE										
		40 PSIG		60 PSIG		80 PSIG		100 PSIG		120 PSIG		
# SPRINGS	POS. 1		40 PSIG		60 PSIG		80 PSIG		100 PSIG		120 PSIG	
	START	END	START	END	START	END	START	END	START	END	START	END
1+1	33	20	90	78	127	115	187	175	239	227	275	263
2+2	65	40	70	45	107	82	167	142	219	194	255	230
3+3	98	60	50	13	87	50	147	110	199	162	235	198
4+4	130	80	--	--	67	17	127	77	179	129	215	165
5+5	163	100	--	--	--	--	107	45	159	97	195	133

PESI - WEIGHT

DOPPIO EFFETTO = 1,25 Kg.
DOUBLE ACTING = 2.76 LB.

SEMPLICE EFFETTO (3+3 molle)= 1.36 Kg.
SPRING RETURN (3+3 spring)= 3.00 LB.

CONSUMI ARIA (CICLO COMPLETO) AIR CONSUMPTION (FULL CYCLE)

DOPPIO EFFETTO = 0,25 N. Lt.
DOUBLE ACTING = 15.26 CU. IN.

SEMPLICE EFFETTO (3+3 molle)= 0,10 N. Lt.
SPRING RETURN (3+3 spring)= 6.10 CU. IN.

