

J3CS Smart Electric Actuator Function: POWER OPEN - POWER CLOSE , STAYS PUT ON POWER FAILURE



E6203S-WRAS

Actuator direct mounted. Max +70C



Main J3/ J3C Smart electric actuator features:

- LED light for continual visual actuator status feedback.
- Fully weatherproof smart industrial actuator.
- Multi-voltage 24-240V capable actuator .
- All external electrical connections, no need to remove cover .
- Selectable manual override facility.
- Thermostatic anti-condensation heater.
- Electronic torque limiter.
- End of travel switches for remote open/ closed indication.
- CE marked.
- EU manufactured by J+J.

Applications:

Water, and most non-corrosive media, subject to compatibility with wetted parts in contact with media. These valves have liners which are approved in the UK by WRAS for use with drinking water (potable water).

Electrical actuators sized on a maximum differential pressure of 10 bar wet service, operated at least once per day. If the intended duty differs from these parameters or is dry (air or gas), call to check JJ actuator sizing as a larger output valve actuator may be required.

Maximum working temperature of a direct mounted assembly is +70C. For higher working temperatures , consider models that have a mounting kit between the valve and actuator which uses air cooling to dissipate the rising heat from the valve away from the actuator. Should the J3CS smart actuator see more than +70C it will malfunction.

Specifications:

Actuator housing	UV Protected Polyamide
Supply voltage range	24-240V AC or DC
IP Rating	IP67
Actuator temp limits	-20 to +70°C
Assembly temp limits	E6203S +70°C Direct mounted E6213S +120°C Mounted via kit
Valve body	Ductile Iron, epoxy coated
Valve disc	Stainless steel
Valve liner	EPDM - WRAS approved
Valve Pressure rating	16 Bar
Valve temp limits	-10 to +120°C
Size range	1" to 12"

Lugged pattern butterfly valve installation information:

Fully lugged and tapped pattern butterfly valves sandwich between two mating flanges, secured by bolts inserted from both sides that screw into the threaded or tapped lugs. See diagram to the right.

The correct alignment of wafer pattern valve so that the butterfly valve's resilient liner seals against the raised faces of the flanges is significantly helped as the securing bolts are inserted from each side, screwing into the threaded or tapped lugs in the butterfly valve. DIN standard butterfly valves typically have metric threaded lugs, ANSI standard butterfly valves will have UNC threaded lugs.

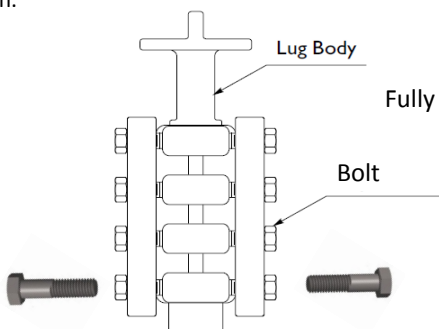

Fully lugged and tapped body, suitable for end of line service

J3CS Smart Electric Actuator Function: POWER OPEN - POWER CLOSE , STAYS PUT ON POWER FAILURE

J3CS ON - OFF ELECTRIC ACTUATOR

Power open, power close, stays put on loss of external power.

How this electric 1/4 turn valve works (on-off):

Electrically operated valves are driven by a motor and gearbox. On receipt of a continuous voltage signal the motor runs and, via a gearbox in the J+J smart electric actuator, rotates the valve stem. The motor stops at the desired position (usually 0° or 90°) by internal cams striking micro-switches. The smart valve actuator remains in this position, with the voltage still applied continuously, until switched and a continuous voltage reversing signal is applied, which runs the motor in the opposite direction, reversing the rotation until separate

Options:

It is possible to change the J3CS actuator's function by installing user friendly pug and play function conversion kits. These will provide the following alternative functions:

Failsafe J3CS Actuator

J3CS fails to pre-set position using our BSR (Battery 'Spring Return' system which creates an alternate power supply should the external power fail.

Modulating J3CS Actuator

Movement of the J3CS actuator is proportional to an input control signal, typically 4-20mA or 0-10V, by installing our DPS (Digital Positioning System) user friendly plug and play kit. There are options for how the J3CS modulating reacts to loss of the control signal, but it will stay put on loss of external power.

Configuration options:

- 1) Closes on loss of control signal
- 2) Opens on loss of control signal
- 3) Stays put on loss of control signal

Failsafe Modulating J3CS Actuator

Failsafe modulating by installing the J+J BSR (Battery 'Spring Return') plug and play kit, operates functionally as a modulating electric actuator as described above, but will fail as per the DPS setting on loss of external power, as follows:

Configuration options:

- 1) Closes on loss of control signal, or on loss of power
- 2) Opens on loss of control signal, or on loss of power
- 3) Stays put on loss of control signal

J3CS ON-OFF & FAILSAFE WIRING (Same connection for either)

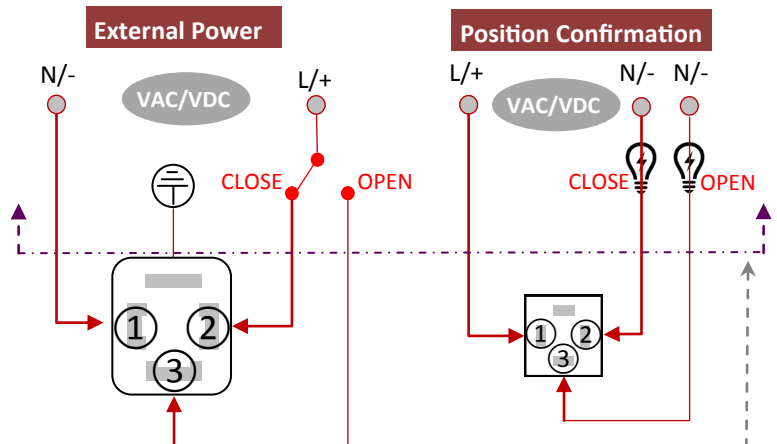

Note: Above line above is customer supplied.

In J+J electric actuators all electrical connections are made externally using the external DIN plugs supplied with the actuator. There is no need to remove the valve actuator's cover to connect electrically. There are no terminals internally to connect to.

Optional Plug & Play Function Conversion Kits

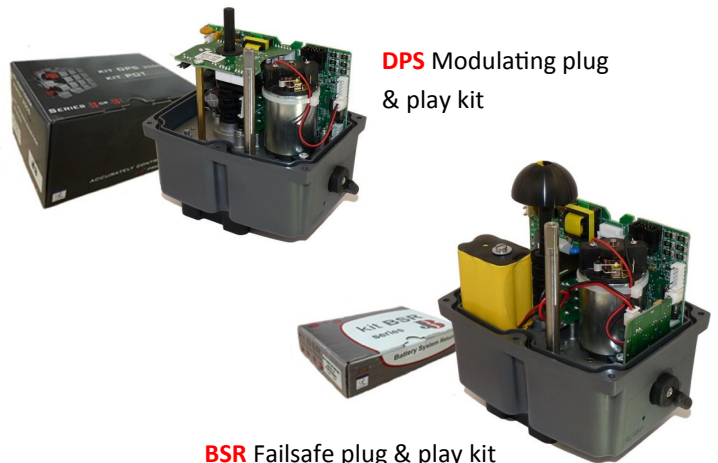

Installing J+J Plug & Play function conversion kits

Failsafe and/or modulating function is quick and easy to achieve in the J3CS smart electric actuator by the fitting of the user friendly failsafe and/or modulating plug & play function conversion kits to the standard on-off J3CS smart valve actuator. When actuated valves are ordered with failsafe, modulating or failsafe modulating function, J+J install and test the plug and play function conversion kits. They can however be easily retro-fitted to J3CS smart electric actuators should the on-off function requirement (supplied as standard function), change.

J3CS Smart Electric Actuator Function: POWER OPEN - POWER CLOSE , STAYS PUT ON POWER FAILURE

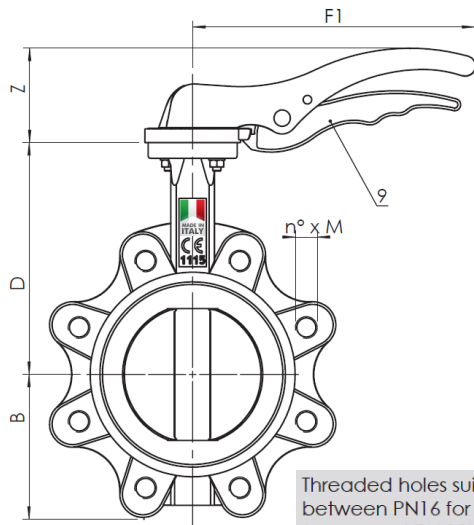

Typical Dimensions & Materials of Construction

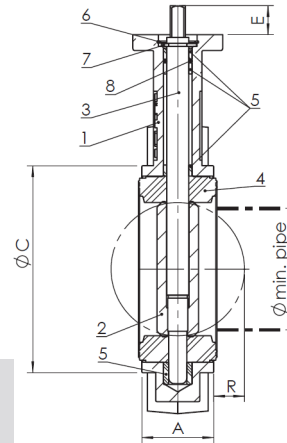

Threaded holes suitable for mounting between PN16 for DN25-300 flanges (on request PN 10) and for mounting between PN 10 for DN 350-600 flanges.

Materials of Construction

Component	Material
1 Body	EN GJS 400 - 15
2 Disc	EN GJS 400 - 15 nickel plated / ASTM A351 gr. CF8-M / CuAl11Fe4 ASTM B148 C94500
3 Stem	AISI 420
4 Liner	EPDM / NBR / FKM (Viton®) / PTFE
5 Bushing	PTFE
6 Washer	Galvanized carbon steel
7 Circlip ISO3075	Spring steel
8 O-ring	FKM (Viton®)
9 Lever	DN25-150 aluminium / DN 200-250 EN GJS 400-15
10 Bolts	Galvanized carbon steel

Typical Dimensions

DN	25	32	40	50	65	80	100	125	150	200	250	300
A	33	33	33	43	46	46	52	56	56	60	68	78
ØC	65	73	82	89	102	118	150	174	205	260	318	376
D	104	110	116	126	136	150	170	180	200	230	266	292
B	51	56	63	62	69	90	106	119	131	166	202	235
F1	192	192	170	170	170	206	206	285	285	400	530	-
Z	68	68	50	50	50	69	69	90	90	72	72	-
F2	130	130	130	130	130	130	130	130	130	235	226	226
L	102,5	102,5	102,5	102,5	102,5	102,5	102,5	102,5	102,5	190	190	190
T	65	65	65	65	65	65	65	65	65	78	80	80
L1	110	110	110	110	110	110	110	110	110	155	170	170
L2	130	130	130	130	130	130	130	130	130	176	200	195
W	45	45	45	45	45	45	45	45	45	63	81	81
O	150	150	150	150	150	150	150	150	150	300	300	300
R	-	1	5	5	9	17	26	34	50	71	91	112
D min pipe	-	12	27	31	45	65	90	110	146	194	241	291
S	7	7	9	9	9	11	11	14	14	17	27	27
E	32	32	21	21	21	21	21	27	27	27	27	27

J3CS Smart Electric Actuator Function: POWER OPEN - POWER CLOSE , STAYS PUT ON POWER FAILURE

Torque Nm

DN	25	32	40	50	65	80	100	125	150	200	250	300
DP bar												
3	2,9	4,7	7,8	11,3	17	23	33	48	68	120	189	290
6	3,1	5,1	8,4	12	18	25	36	54	78	134	212	316
10	3,3	5,4	8,8	13	20	26	40	61	88	148	234	342
16	3,4	5,7	9,2	13	21	28	44	68	99	162	257	367

Note: For sizing of actuators, multiply the above 16 bar torques by 1.5 for wet service, and by 2 for dry service (air or gas).

To use 3, 6 or 10 bar differential pressure torques, and factory option undercut disc is required. Contact us for details for further details.

Pressure x Temperature Chart

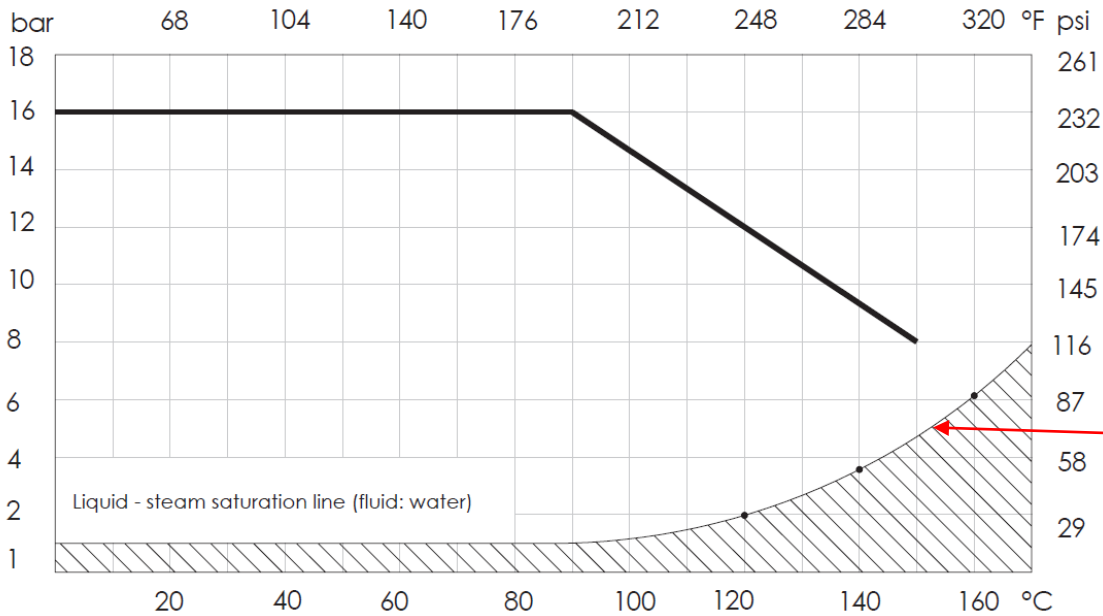

Head Loss Diagram (with disc fully open) Fluid: Water . NB: 1m of water = 0.098bar

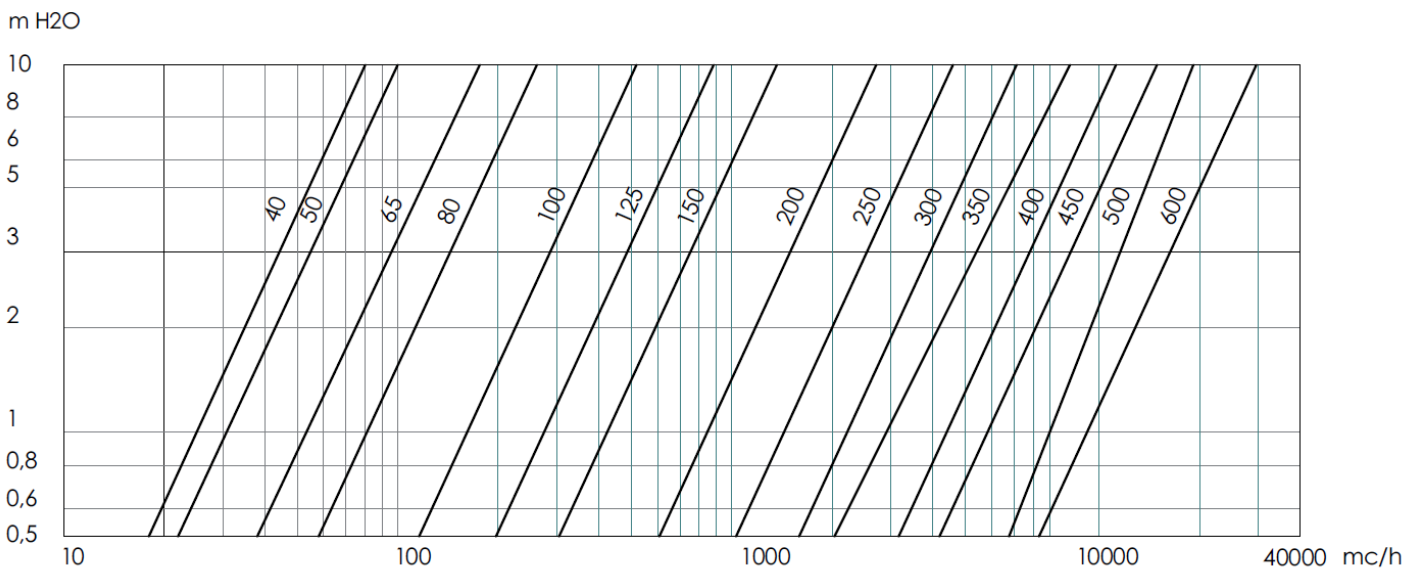

J3CS Smart Electric Actuator Function: POWER OPEN - POWER CLOSE , STAYS PUT ON POWER FAILURE

Flow rate indication depending on opening angle

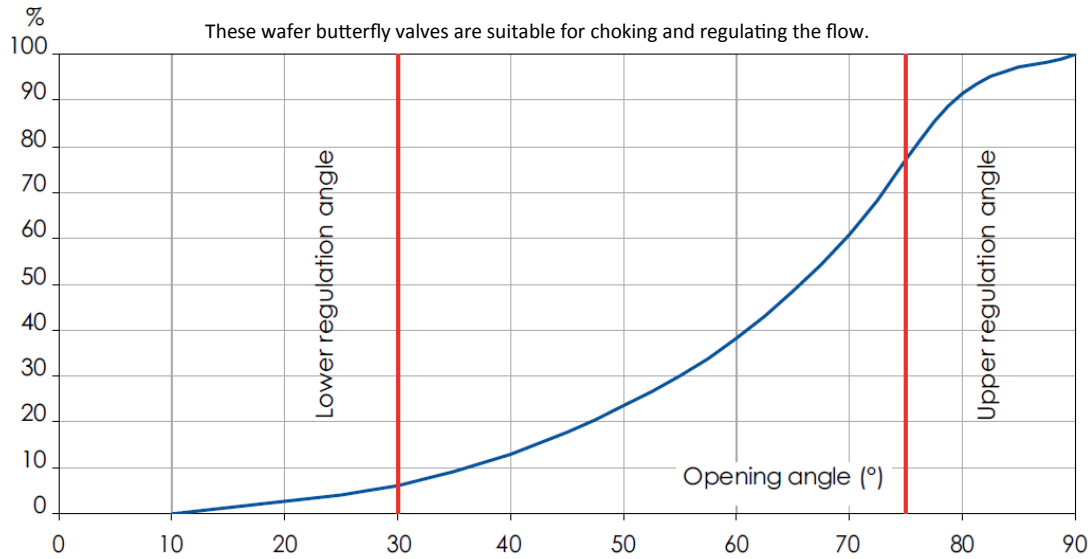

Flow Chart (Kv in m³/hr at 1 bar pressure drop)

DN	mm	40	50	65	80	100	125	150	200	250	300
	ins	1" 1/2	2"	2" 1/2	3"	4"	5"	6"	8"	10"	12"
OPENING ANGLE	10°	0,04	0,05	0,09	0,17	0,26	0,43	0,69	1,73	2,6	3,5
	20°	2,1	2,6	5,2	7,8	15	25	39	77	130	202
	30°	4,8	6	10	16	31	53	82	162	276	427
	40°	10	13	22	34	67	115	177	352	599	926
	50°	19	23	39	60	120	205	316	628	1068	1650
	60°	30	38	65	100	199	339	522	1038	1768	2730
	70°	48	60	103	158	314	535	827	1643	2798	4322
	80°	73	91	161	237	471	803	1241	2465	4196	6483
	90°	79	99	169	261	518	883	1364	2708	4611	7124

Applicable Standards

CE In conformity with directive 97/23/CE PED
In conformity with D.M. 174 (directive 97/83/CE)

Construction and testing norms (correspondences):

Face-to-face: EN558/1-20 (ISO 5752-20, DIN 3202K1)

Flanges: EN1092, ANSI B16.5 #150

Design: EN593, EN13445, ISO 5211, EN12570

Marking: EN19

Testing: 100% testing in accordance with EN 12266 cat. A (ISO 5208 cat. A)

Application Areas



WATER



CONDITIONING



GAS



HEATING
BUT NOT
STEAM



DRINKING WATER



INDUSTRY



MARINE



FIRE FIGHTING

WRAS
APPROVED
PRODUCT