

Nº	Descripción Description	Canl. Quant.	Materia Material
1	TORNILLO ALLEN TAPA CAP ALLEN SCREW	8	ACERO INOX. AISI-316 AISI-316 STAINLESS STEEL
2	TAPA DOBLE EFECTO DOUBLE ACTING CAP	2	ACERO INOXIDABLE CF8M CF8M STAINLESS STEEL
3	JUNTA TORICA TAPA CAP O-RING	2	N.B.R.
4	EMBOLO PISTON	2	POLIARILAMIDA POLYARILAMIDE
5	CILINDRO CYLINDER	1	ACERO INOXIDABLE CF8M CF8M STAINLESS STEEL
6	ARANDELA WASHER	1	POLIAMIDA 6 POLYAMIDE 6
7	ANILLO DE SEGURIDAD SPRING CLIP	1	ACERO INOXIDABLE STAINLESS STEEL
8	INDICADOR VISUAL POSITION INDICATOR	1	POLIAMIDA POLYAMIDE
9	GUIA EMBOLO PISTON GUIDE	2	POLIACETAL POLYACETAL
10	ANILLO GUIA GUIDE RING	2	POLIACETAL POLYACETAL
11	JUNTA TORICA EMBOLO PISTON O-RING	2	N.B.R.
12	JUNTA TORICA EJE SHAFT O-RING	2	N.B.R.
13	JUNTA TORICA EJE SHAFT O-RING	2	N.B.R.
14	JUEGO MUELLES PRECARGADOS PRELOADED SPRINGS SET	1	DIN-17223-C (2) (4) DIN-17223-C (2) (4)
15	TAPA SIMPLE EFECTO SPRING RETURN CAP	2	ACERO INOXIDABLE CF8M CF8M STAINLESS STEEL
16	EJE SHAFT	1	ACERO INOX AISI-316 AISI-316 STAINLESS STEEL
17	PINON GEAR	1	ALEACION ALUMINIO (5) (2) ALUMINIUM ALLOY (5) (2)
18	JUNTA TORICA PLACA PLATE O-RING	2	N.B.R.
19	JUNTA TORICA TAPA CAP O-RING	2	N.B.R.
20	PLACA CONEXIÓN NEUMÁTICA PNEUMATIC CONNECTION PLATE	1	ACERO INOXIDABLE CF8M CF8M STAINLESS STEEL
21	TORNILLO ALLEN PLACA PLATE ALLEN SCREW	2	ACERO INOXIDABLE AISI-316 AISI-316 STAINLESS STEEL
22	TORNILLO BOLT	2	ACERO INOXIDABLE AISI-316 AISI-316 STAINLESS STEEL
23	TUERCA NUT	2	ACERO INOXIDABLE AISI-316 AISI-316 STAINLESS STEEL
24	ARANDELA BUSHING	2	ACERO INOXIDABLE AISI-316 AISI-316 STAINLESS STEEL
25	JUNTA TORICA O-RING	2	N.B.R.
26	LEVA CAM	1	ACERO INOXIDABLE CF8 CF8 STAINLESS STEEL

CF8M STAINLESS STEEL
PNEUMATIC ACTUATOR

PI20: Doble Efecto / Double Acting

PI20S: Simple Efecto / Spring Return

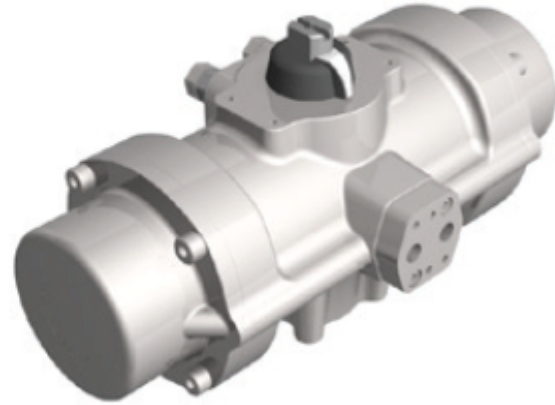

- (2) RECUBRIMIENTO POR CATAFORESIS.
COVERED BY CATHORESIS.
- (4) CANTIDAD VARIABLE, CONSULTAR TABLAS PARES SIMPLE EFECTO.
VARIABLE QUANTITY, PLEASE SEE THE SPRING RETURN TORQUE CHART.
- (6) BRUNIDO CON BOLAS.
BALL BURNISHING.

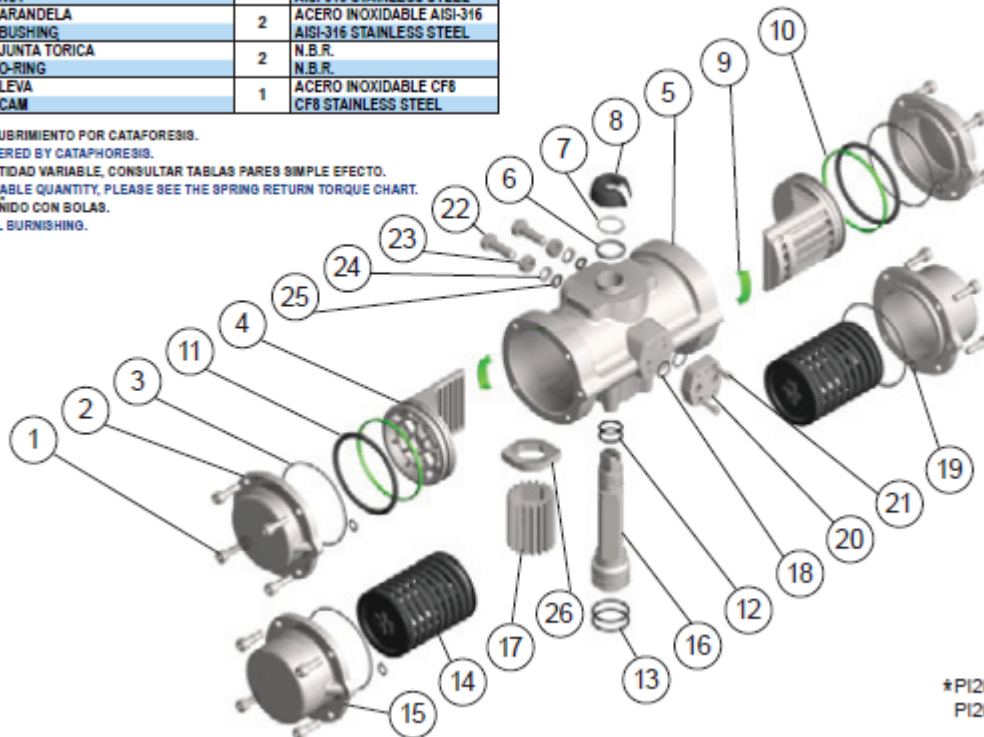

*PI20: SIL2
PI20S: SIL3

MODELOS MODELS	TIEMPO DE MANIOBRA EN SEG. CYCLE TIME IN SECS.		PESOS WEIGHTS		CAPACIDAD EN LITROS CAPACITY IN LITRES	
	PARA ABRIR TO OPEN	PARA CERRAR TO CLOSE	Kg.	Lb.	PARA ABRIR TO OPEN	PARA CERRAR TO CLOSE
PI20	0,4	0,4	5,9	13,01	0,8	0,7
PI20S	0,5	0,5	9,9	21,83	0,8	

Tiempo de maniobra sin par resistente a 6 bar.
Cycle time w/o resistant torque at 6 bar.

Dimensiones en mm.
Dimensions in mm.

Para calcular el consumo, multiplicar las cifras del cuadro por la presión real de trabajo.

To calculate the consumption, multiply the above figures by the real working pressure.

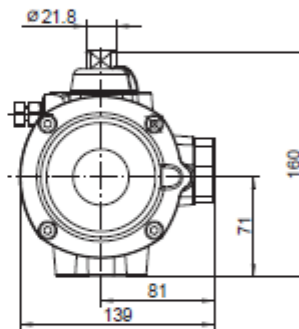
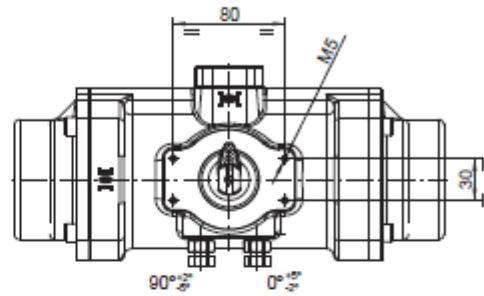
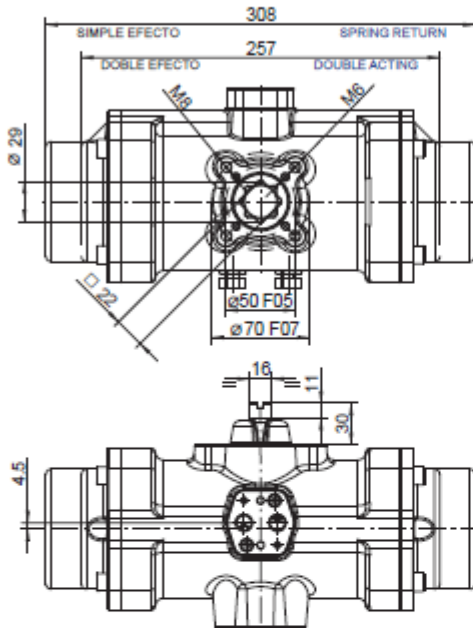

**PARES DOBLE EFECTO
DOUBLE ACTING TORQUES**

PI20	PRESION AIRE AIR PRESSURE							
	3	4	5	5,5	6	7	8	
bar	43,5	58	72,5	79,8	87	101,5	116	
p.s.i	77,7	107	136,3	150,9	165,5	194,8	224	
Nm	687,8	947,3	1.206	1.335	1.465	1.724	1.983	
Lb.in								

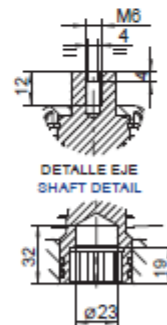
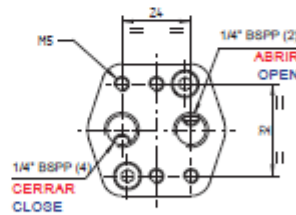

**PARES SIMPLE EFECTO
SPRING RETURN TORQUES**

PI20S	PAR MUELLES SPRING TORQUES		PAR A LA PRESIÓN INDICADA AIR TORQUE AT INDICATED PRESSURE															
			3		4		5		5,5		6		7		8		bar	
				43,5		58		72,5		79,8		87		101,5		116		p.s.i
N	INICIAL INITIAL	FINAL END	INICIAL INITIAL	FINAL END	INICIAL INITIAL	FINAL END	INICIAL INITIAL	FINAL END	INICIAL INITIAL	FINAL END	INICIAL INITIAL	FINAL END	INICIAL INITIAL	FINAL END	INICIAL INITIAL	FINAL END		
3	104,7	65,8					70,5	32	85,1	46,4	99,7	60,8	129	90,1	158,2	119	Nm	
	927	582,3					623,8	279,6	753,4	409,1	882,9	538,6	1142	797,5	1400	1056	Lb.in	
2	71,8	44,9			62,1	35,2	91,4	64,5	106	79,1	120,6	93,7	149,9	123	179	152	Nm	
	635,4	397,4			549,9	311,9	808,8	570,7	938,6	700,3	1068	829,8	1327	1088	1585	1347	Lb.in	
1	49,7	32,9	44,8	29,8	74,1	59,1	103,4	88,4	118	103	132,6	117,6	161,9	146,9	191	176,1	Nm	
	423,9	291,2	396,7	263,9	656,1	523,4	915	782,3	1044	911,3	1174	1041	1433	1300	1691	1559	Lb.in	

N: Número de muelles por banda
Number of springs per side

* Número de muelles estándar
* Standard number of springs