

Nº	Descripción Description	Cant. Quant.	Materia Material
1	TORNILLO HEXAGONAL TAPA HEXAGONAL SCREW	8	ACERO INOX. AISI-316 AISI-316 STAINLESS STEEL
2	TAPA CAP	2	ACERO INOXIDABLE CF8M CF8M STAINLESS STEEL
3	JUNTA TÓRICA TAPA CAP-O-RING	2	N.B.R. N.B.R.
4	EMBOLO PISTON	2	ALEACION ALUMINIO (2) ALUMINIUM ALLOY (2)
5	CILINDRO CYLINDER	1	ACERO INOXIDABLE CF8M CF8M STAINLESS STEEL
6	ARANDELA WASHER	1	POLIAMIDA 6 POLYAMIDE 6
7	ANILLO DE SEGURIDAD SPRING CLIP	1	ACERO INOXIDABLE STAINLESS STEEL
8	INDICADOR VISUAL POSITION INDICATOR	1	POLIAMIDA POLYAMIDE
9	GUIA EMBOLO PISTON GUIDE	4	POLIACETAL POLYACETAL
10	ANILLO GUIA GUIDE RING	2	P.T.F.E + BRONCE P.T.F.E + BRONZE
11	JUNTA TÓRICA EMBOLO PISTON O-RING	4	N.B.R. N.B.R.
12	JUNTA TÓRICA EJE SHAFT O-RING	2	N.B.R. N.B.R.
13	JUNTA TÓRICA EJE SHAFT O-RING	2	N.B.R. N.B.R.
14	JUEGO MUELLES PRECARGADOS PRELOADED SPRINGS SET	1	DIN-17223-C (2) (4) DIN-17223-C (2) (4)
15	ARGOLLA HOOP	2	ACERO INOXIDABLE AISI-316 AISI-316 STAINLESS STEEL
16	EJE SHAFT	1	ACERO INOX AISI-316 AISI-316 STAINLESS STEEL
17	PINON GEAR	1	ALEACION ALUMINIO (5) (2) ALUMINIUM ALLOY (5) (2)
18	JUNTA TÓRICA PLACA PLATE O-RING	2	N.B.R. N.B.R.
19	JUNTA TÓRICA TAPA CAP O-RING	2	N.B.R. N.B.R.
20	PLACA CONEXIÓN NEUMÁTICA PNEUMATIC CONNECTION PLATE	1	ACERO INOXIDABLE CF8M CF8M STAINLESS STEEL
21	TORNILLO ALLEN PLACA PLATE ALLEN SCREW	2	ACERO INOXIDABLE AISI-316 AISI-316 STAINLESS STEEL
22	TORNILLO BOLT	2	ACERO INOXIDABLE AISI-316 AISI-316 STAINLESS STEEL
23	TUERCA NUT	2	ACERO INOXIDABLE AISI-316 AISI-316 STAINLESS STEEL
24	ARANDELA BUSHING	2	ACERO INOXIDABLE AISI-316 AISI-316 STAINLESS STEEL
25	JUNTA TÓRICA O-RING	2	N.B.R. N.B.R.
26	LEVA CAM	1	ACERO INOXIDABLE AISI-304 AISI-304 STAINLESS STEEL
27	ARANDELA WASHER	8	ACERO INOXIDABLE AISI-316 AISI-316 STAINLESS STEEL

- (2) RECUBRIMIENTO POR CATAFORESIS.
COVERED BY CATHAPHORESIS.
- (4) CANTIDAD VARIABLE. CONSULTAR TABLAS PARES SIMPLE EFECTO.
VARIABLE QUANTITY, PLEASE SEE THE SPRING RETURN TORQUE CHART.
- (6) BRUNIDO CON BOLAS.
BALL BURNISHING.

CF8M STAINLESS STEEL
PNEUMATIC ACTUATOR

PI40: Doble Efecto / Double Acting

PI40S: Simple Efecto / Spring Return

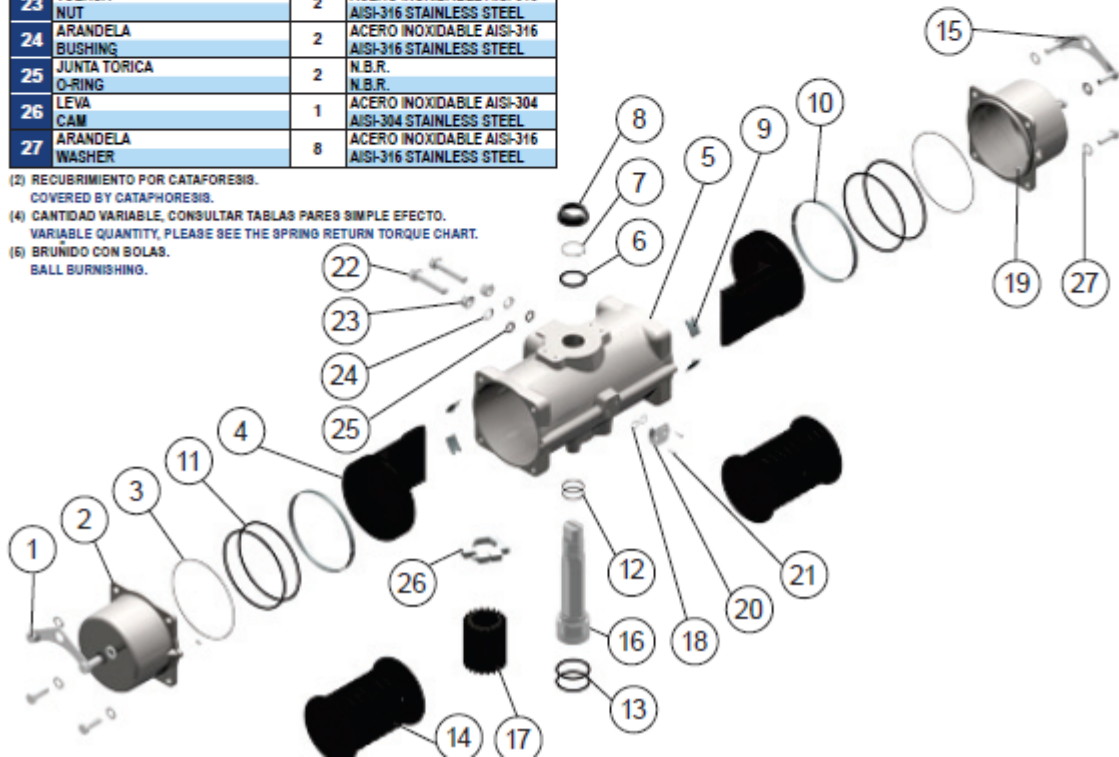
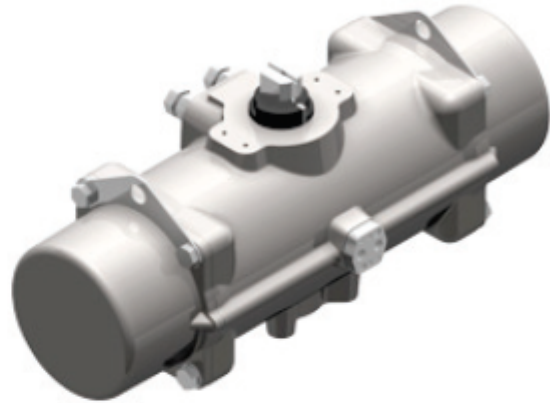

MODELOS MODELS	TIEMPO DE MANIOBRA EN SEG. CYCLE TIME IN SECS.		PESOS WEIGHTS		CAPACIDAD EN LITROS CAPACITY IN LITRES	
	PARA ABRIR TO OPEN	PARA CERRAR TO CLOSE	Kg.	Lb.	PARA ABRIR TO OPEN	PARA CERRAR TO CLOSE
	PI40	1,2			1,2	38,40
PI40S	2	2	57,60	126,99	5,3	

Tiempo de maniobra sin par resistente a 6 bar.
Cycle time w/o resistant torque at 6 bar.

Dimensiones en mm.
Dimensions in mm.

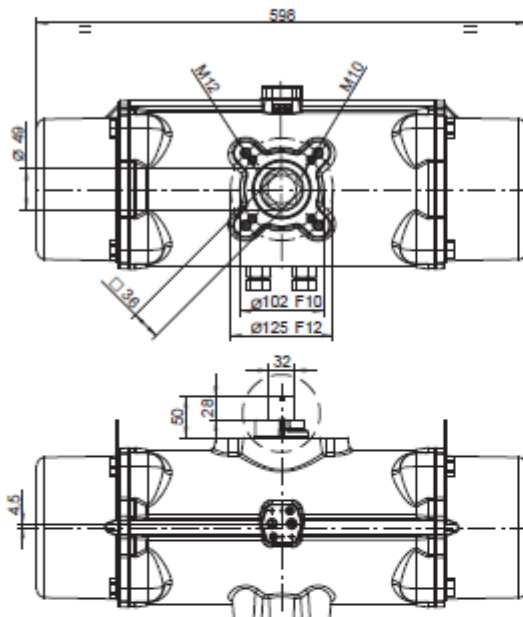

Para calcular el consumo, multiplicar las cifras del cuadro por la presión real de trabajo.

To calculate the consumption, multiply the above figures by the real working pressure.

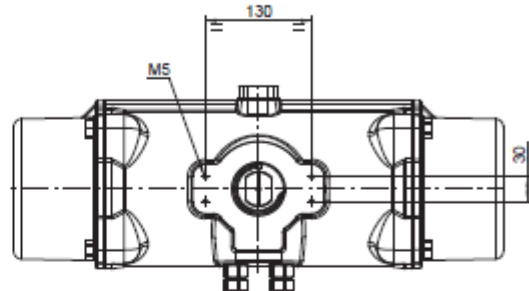

**PARES DOBLE EFECTO
DOUBLE ACTING TORQUES**

PI40	PRESION AIRE AIR PRESSURE						
	3	4	5	5,5	6	7	8
bar	3	4	5	5,5	6	7	8
p.s.i	43,5	58	72,5	79,8	87	101,5	116
Nm	582,5	782	980,8	1.080	1.180	1.379	1.578
Lb.in	5.155	6.917	8.680	9.560	10.442	12.204	13.967

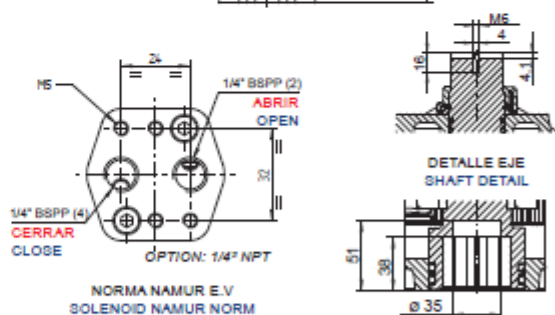

**PARES SIMPLE EFECTO
SPRING RETURN TORQUES**

PI40S	PAR MUELLES SPRING TORQUES	PAR A LA PRESIÓN INDICADA AIR TORQUE AT INDICATED PRESSURE															
		3		4		5		5,5		6		7		8		bar	
		43,5	58	72,5	79,8	87	101,5	116								p.s.i	
N	INICIAL INITIAL	FINAL END	INICIAL INITIAL	FINAL END	INICIAL INITIAL	FINAL END	INICIAL INITIAL	FINAL END	INICIAL INITIAL	FINAL END	INICIAL INITIAL	FINAL END	INICIAL INITIAL	FINAL END	INICIAL INITIAL	FINAL END	
4*	766,9	491,6			489,1	213,8	588,4	313,4	688,3	413	887,4	612,1	1.087	811,3		Nm	
	6.787	4.351			4.329	1.892	5.207	2.773	6.091	3.655	7.854	5.417	9.616	7.180		Lb.in	
3	629,3	432,6		349,4	152,7	548,1	351,5	647,7	451,1	747,3	550,6	946,4	749,8	1.146	948,9		Nm
	5.569	3.829		3.092	1.352	4.851	3.111	5.732	3.992	6.613	4.873	8.376	6.635	10.138	8.398		Lb.in
2	452,3	314,6	267,9	130,2	467,4	329,7	666,1	528,5	765,7	628,1	865,3	727,6	1.064	926,8			Nm
	4.003	2.785	2.370	1.152	4.136	2.918	5.895	4.677	6.776	5.558	7.658	6.439	9.420	8.202			Lb.in
1	275,3	177	405,5	307,2	605	506,7	803,8	705,5	903,4	805,1	1.003	904,6					Nm
	2.436	1.566	3.589	2.718	5.355	4.485	7.113	6.243	7.995	7.125	8.876	8.006					Lb.in

N: Número de muelles por banda
Number of springs per side

* Número de muelles estándar
* Standard number of springs